

低空頭部障害撤去作業フロー

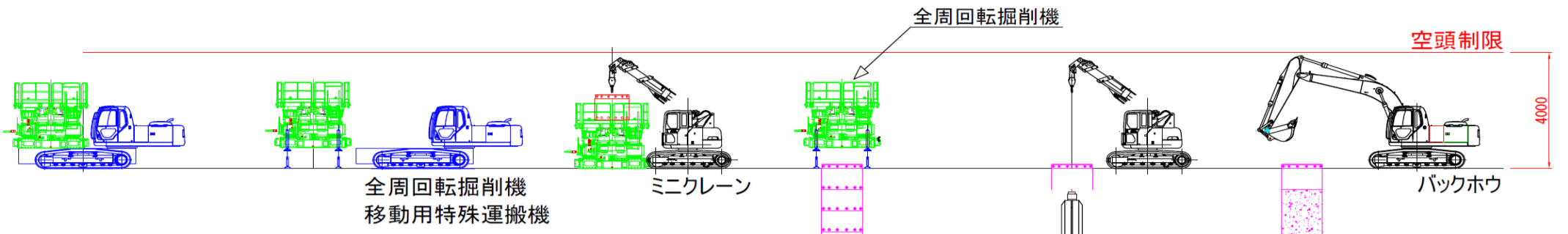

施工フロー

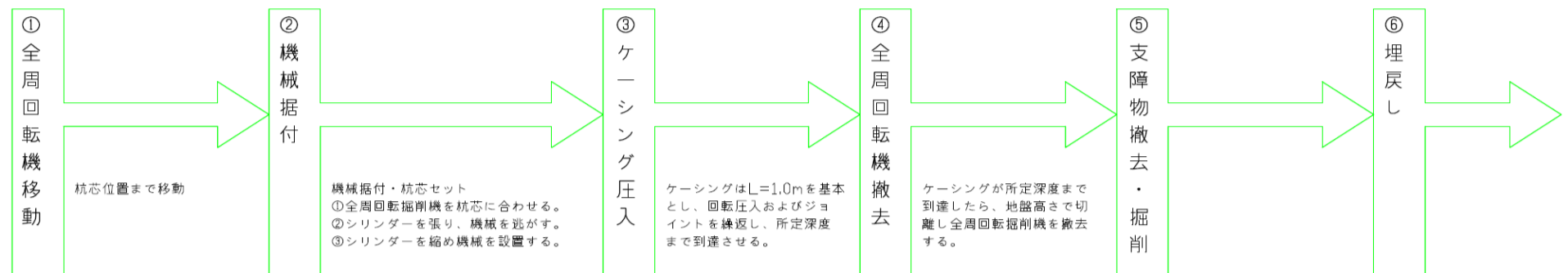

※杭芯セット

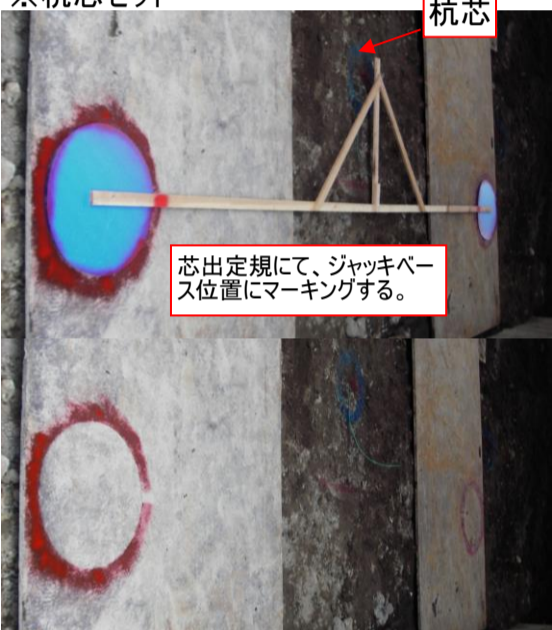

③ケーシングジョイント



④全周回転機撤去



⑤支障物撤去・掘削



⑥埋戻し



①全周回転掘削機据付



ケーシング引抜き(全周回転機再据付け)



ケーシング切離し

